

ON DEVELOPMENT OF THE SUPER-SINGLE DRIVE (GMD) TYRE

Kenshiro Kato
Kuninobu Kadota

Bridgestone Corp., 3-1-1 Ogawahigashi, Kodaira, Tokyo 187-8531, Japan
Bridgestone Corp., 3-1-1 Ogawahigashi, Kodaira, Tokyo 187-8531, Japan

ABSTRACT

Technical ingredients for replacing dual mounting of truck and bus tyres with the single wide base tyre (GMD:GREATEC Mega Drive) are presented. Aim of developing the technology is underlined by directing dramatic enhancement of tyre durability to advantages on economy, environment and vehicle utility: reduced rolling resistance to benefit energy efficiency, less tyre weight to save limited resources on earth, less tyre room occupied to enable new vehicle designs. Technical issues in the tread area were uneven growth due to wide sectional configuration and large stress concentration. While in the bead area, large strain induced by considerable deflection should effectively be minimized. To overcome the difficulties innovative structures were proposed. The results showed outstanding performance under critical testing conditions.

INTRODUCTION

As recognized widely in global industrial societies, proactive technology should be adopted on ecological and economical issues when developing new products. Heavy commercial vehicles such as trucks, trailers and buses have already started including the idea by aiming at: less energy consumption and less exhaust emission leading ultimately to hybrid and/or fuel cell engine systems, higher efficiency in transporting cargos. One of the crucial components of the vehicle, the tyre, should also respond to the requirements of the social needs; effort to fulfil simultaneously ecology- and economy-consciousness and high quality of tyre performance is needed. More specifically, lower rolling resistance, less weight (less amount of raw material used), and lower tyre noise and so on, should be pursued without sacrificing fundamental performance such as durability, tread wear and manoeuvrability.

No doubt considerable effort has been made to date in tyre design; economy-efficient and environmentally-correct materials are mostly used, various tyre designs of carcass configuration, structure and tread pattern, which effectively reduce rolling resistance and achieve weight reduction, are employed.

Now as a remaining but a very hopeful approach to meet the needs, we focus on the mounting system of dual tyres on drive and non-steer axles of the heavy vehicles, and intend to replace these tyres with single wide-base tyre of less volume, see Figure 1. This concept, named GREATEC Mega Drive (GMD), assumes considerable enhancement of durability for the single tyre. Following this strategy, if concentration of stress and strain can successfully be suppressed, lower rolling resistance can be obtained because the GMD uses less amount of hysteretic material (rubber).

On the premise that the GMD clears all requirements of the tyre performance, the concept could motivate innovative and flexible vehicle design. For instance, a wider room on the axle might enable installation of a high-tech engine/braking system, comfortable passenger cabin and large cargo space (see Fig.2). Even when designing a vehicle with narrower width, e.g. luxurious petit-bus, ample cabin space could be retained. Of course, the use of wider wheel indicates the possibility of equipping a wheel-in motor system.

This paper describes technical effort to search advanced structures for the wide base tyre with special emphasis on durability performance, on which the GMD concept is grounded.

TECHNICAL TASKS FOR DEVELOPING THE SUPER-SINGLE (GMD) TYRE

The GMD tyre has less volume enclosed by the tyre outer surface and the rim base than the sum of the dual tyres. It means that the nearly identical vertical load, the driving torque and the side force act on the smaller envelope causing larger deformation. To meet the nearly doubled loading, the air pressure could be raised. For example of the GMD concept, which replaces the dual 315/70R22.5 tyres with the single 495/45R22.5 GMD tyre, the vertical

load and the air pressure are specified in the European Tyre and Rim Technical Organisation (ETRTO) standards manual respectively as 56.84kN and 900kPa compared to 30.87kN and 850kPa of 315/70R22.5. Though the load is not exactly doubled in the standards, the GMD tyre is subjected to 84 percent more load than the single 315/70R22.5 with only 6 percent increase of the air pressure and 57 percent increase of the tyre width (overall diameter is virtually equal in the both tyres). In fact, the tyre deflection of 495/45R22.5 is larger than its counterpart by 51 percent. Thus, the ability to bear the increased load and the increased air pressure is demanded.

Tasks for belt package structure

In the tread area of the tyre, large deformation and heat generation are the main cause of belt failure and uneven growth. Conversely, the non-uniform growth of the tread is a cause of the heat generation and the stress concentration leading to the early failure, and a cause of the uneven wear as well. The growth is due to the pressurisation of the tyre and the creep behaviour under various service conditions.

In mechanical theory of the radial tyre, if all fibre-reinforced members are assumed to be inextensible, the belt package produces the tensional force by pressurisation in the equatorial (or circumferential) direction: the force is roughly proportional to the coordinate difference in the radial direction between the equilibrated carcass (or ply) without the belt and the original coordinate of the belt [1]. Therefore, the tyre with lower aspect ratio (tyre width divided by tyre height in the meridian section plane) has larger belt force produced by pressurisation and hence larger shear strain between belt layers than the tyre with higher aspect ratio. The GMD is obviously bound for the very low aspect ratio. In our knowledge of engineering practice, the mechanism of belt deformation as consulted with the developed belt forces is indeed of great significance [2,3].

The conventional belt package (Fig. 3) is characterised as the structure of multiple layers of composites: each layer is made of uni-directionally oriented yarned steel cords and coating rubber in between, the steel cord forms the angle of 15 to 60 degrees to the equator line, a couple of adjacent layers are crossed each other. Such a composite, known as the Fibre Reinforced Rubber, excels in deformability and damping characteristics especially when impact forces are transmitted from the ground. However, as the belt force develops by lowering the aspect ratio, the conventional belt indicates the unbalance of the growth across the tread (Fig.4). Consequently, a high concentration of the inter-laminar shear strain is generated at the belt edge.

To solve the problem, the rigidity in the circumferential direction needs to be increased dramatically. After a long course of research we came to the conclusion that the wavy steel cord coated by polymer (the WAVED), which has a number of regulated waves in the plane of the belt layer with its wave length λ and wave amplitude a , is suited and performs excellent. The WAVED belt layer behaves like a nonlinear spring. First, the concentration of shear strain due to the rigidity gap between adjacent conventional layers can effectively be relaxed by its spring-like movement. Further, the tread growth can be controlled directly and smoothly by setting appropriate λ and a . This idea is very useful and is protected by a series of international patents.

The typical WAVED belt structure currently used is a combination of the WAVED layers and the conventional layers (see Fig.3), where the belt tension in the WAVED layers is nearly comparable to that in the conventional layers. The current WAVED belt performs better than its counterpart (Fig.4 and Fig.5). However, as we go beyond the aspect ratio lower than 0.60, the current WAVED belt should be revised to achieve the uniform growth and the durability life equivalent to the aspect ratio 0.70.

Tasks for bead structure

The GMD strategy requires the bead also of a considerable progress. From the conventional dual tyres to the GMD, the load per tyre increases larger than the increase of the contact area with the ground and the increase of the air pressure. Therefore, the GMD tyre deflects 51 percent more, and a very large deformation develops in the sidewall to the bead area. As the deformation in the right-under-the-load section shows that the outer surface of the bead is compressed hard against the rim flange, a large shear strain builds up in the vicinity of the failure point.

On the other hand, fractography analysis concluded that circumferential shear is another cause of failure. This behaviour is apparent in the bead area corresponding to the edge of the contact patch (with the ground).

The conventional bead (Fig. 6, right) is the structure characterised in that: the radial carcass (ply) is turned up past the bead core (a wire bundle oriented to the circumferential direction), a couple of FRR layers and rubbers of high modulus are deployed to suppress the strains. Figure 6 shows that the durability deteriorates as the aspect ratio goes lower. The drastic drop below the aspect ratio 0.50 can be interpreted as firstly that the ability to bear the load (the load index) is actually raised in the ETRTO standards, consequently the strains relevant to failure

increase. Secondly, the circumferential shear deformation develops rapidly; the tyre sidewall tends to shear as its rigidity (effect of tension included) decreases relative to the belt, clearly large belt force builds up with the low aspect ratio. More straightforwardly for the GMD concept, the halved number of the sidewall causes serious difficulty. In general, the effect of the circumferential shear is further typified when the fore-and-aft forces act on the tyre.

Thus, the GMD strategy demands approximately the three times enhancement of the durability (Fig. 6).

RESEARCH METHODOLOGY

Research was conducted so as to get insight into important relations between: fractural behaviour and relevant strains, tyre deformation and strains, crack propagation and strains and temperature. The first relation was investigated by the failure analysis of the tested tyres, and synchronously a number of specimen tests were carried out in the laboratory to identify the failure mode and the influence of the stress and the temperature [4,5]. The strain was calculated using the finite element method (FEM), in which the nonlinear time-dependent analysis [6,7] with the scrupulous FE-model (Fig. 7) was conducted. Modelling of the WAVED belt was particularly elaborated. Temperature distribution was also assessed by the stress and the strain field using the FEM and was compared with experimental data. The second was carried out mainly by using the FEM, and was supplemented by experiments to prove hypotheses. The last owed to numerous specimen tests. Effects of material degradation due to heat build-up and oxidization were also considered.

For the purpose of verification, ample amounts of laboratory tests, drum tests and field tests of the GMD tyres were conducted.

ESTABLISHMENT OF THE GMD-TECHNOLOGY

As a consequence of the research, the correlation between the crack growth rate and the dominant strain for every failure mode, and the correlation between the crack growth rate and the temperature were found out quantitatively. In ensuing optimisation, the following structures were proposed.

New Waved belt

Figure 8 typically shows the family of the belt package (the New WAVED belt) proposed for the GMD tyre. Main points of alteration from the current WAVED belt are: the waved layers deployed on the inner side of the tyre, the widened waved belt, and the optimised rigidity of the conventional belt layers. The first and the third alteration are because the inter-laminar shear strain between the conventional belt layers reduces substantially. The second obviously suppresses the uneven growth due to pressurisation and the creep of the tyre. This was proven to be effective especially when the aspect ratio is below 0.70. The third is also directed for taking advantages in manoeuvrability and resistance to foreign object damage (FOD).

In Fig. 9, the Von Mises stress is depicted to show the tendency to creep. The New WAVED belt yields remarkable reduction of the stress, which can retard crack initiation and propagation.

Turn-In-Ply (TIP) bead

One candidate is obtained by laying reinforcements (FRR) correctly onto the conventional turn-up-carcass end. In fact, the reinforcements have significant effect on reducing the circumferential shear deformation and on dispersing the stress concentration right under the load.

Another is achieved by turning in the carcass around the bead core (Turn-In-Ply bead: TIP, see Fig.10). The rational is to move the expected point of failure (carcass end) away from the area of high gradient of deformation. Actually, the conventional bead suffers this point, hence needs protective layers additionally. The TIP bead excels in the moderate strain field, which can clearly be observed in Fig. 11. The figure schematically shows the principal strain under pressurised and loaded condition. The tyre is assumed to be exposed to the thermal aging, the process of keeping pressurised tyre in the environment of a high temperature, say approximately six days in a chamber of 80 degrees Celsius. Therefore, the creep behaviour is mainly simulated.

A significant reduction of the strain is observed in the proposed structures.

RESULTS AND DISCUSSIONS

The GMD concept was verified in the following for the 435/45R22.5 and the 495/45R22.5 tyres, which are the replacement of the dual mount of 275/70R22.5 and 315/70R22.5 respectively.

For the growth due to pressurisation, the GMD yields the growth ratio at the tread centre approximately 0.6 percent and at the maximum point 0.7 percent, the distribution of the growth is virtually flat, cf. Fig. 4. Still, under a typical service condition, the uniformity of the tread growth can be maintained within 0.1 percent of the difference between the tread centre and the maximum point. This differs from the growth of the current WAVED belt remarkably. The data was confirmed by good performance on wear.

As for the durability, the major challenge of the GMD development, the following results were obtained in drum tests. Belt durability test indicates for the New WAVED belt the index of 107 as referred to Fig. 5, which is far beyond the required level. For the bead durability, the reinforced conventional-type bead and the TIP bead show respectively the indexes of 98 and 110 as referred to Fig. 6. The proposed bead structures are satisfactory as compared with the tyre of the aspect ratio 0.70. Reliable durability was again confirmed in the critical drum test, in which the effect of material degradation was considered.

As can be expected from GMD's narrower tyre width and larger belt tension than the dual tyre system, the contact area with the ground under static condition reduces approximately by 13 percent. This leads directly to the increase of the contact pressure, and then to the concern for the damage to the road. However, the GMD tyre has the vertical spring constant 25 percent lower than its counterpart, which seems to represent dynamic behaviour correctly. This can generally be understood as follows: the deformation of the belt ring is determined by the balance of the belt and the sidewall rigidity (tensional force), the rigidity of the sidewall relatively decreases due to the reinforced New WAVED belt, the tyre tends to deflect eccentric with weakening the spring constant. As a consequence, the GMD tyre excels in the FOD test, where plunger head is pressed hard against the tyre tread to measure the stored energy to failure.

Advantages of the GMD concept were solidified as compared with the current dual mount in that: the rolling resistance reduced approximately by 10 percent excluding the effect of rubber properties, the weight reduction including the tyre and the rim was achieved by 80 to 110 kg per axle, the material used for building the tyre reduced by 20 to 25 percent, the space occupied in single tyre house reduced more than 15 cm.

Vehicle tests revealed that the manoeuvrability of the GMD tyre on both dry and wet surfaces was nearly equal to the dual tyres. The riding comfort, the performance of the wear, and the resistance to irregular wear were also equivalent.

CONCLUSION

Technological challenge initially posted for the GMD strategy was addressed. By suppressing the concentration of the stress and the strain, the durability of the GMD tyre was successfully enhanced. In other terms, the novel structures, the New WAVED belt and the TIP bead, were proposed and proven to be excellent. Indeed, all consequences owed to clear understanding of the physics and to the spirit of innovation.

The established technology could be helpful to evolve into further stages of tyre development.

REFERENCES

- [1] T. Akasaka: "Structural Mechanics of Radial Tires", *Rubber Chemistry and Technology*, Vol. 54, pp.461-492, 1981.
- [2] S.K. Clark, editor: *Mechanics of Pneumatic Tires*, U.S. Department of Transportation, 1982.
- [3] S.Y. Luo, T.W. Chou: "Finite Deformation and Nonlinear Elastic Behaviour of Flexible Composites", *Journal of Applied Mechanics*, Vol. 55, pp.149-155, 1988.
- [4] G.J. Lake: "Fatigue and Fracture of Elastomers", *Rubber Chemistry and Technology*, Vol. 68, pp.435-460, 1995.
- [5] R.W. Smith: "The Microscopy of Catastrophic Tire Failures", *Rubber Chemistry and Technology*, Vol. 70, pp.283-293, 1997.
- [6] K.J. Bathe: *Finite Element Procedures*, Prentice Hall, Englewood Cliffs, New Jersey, 1996.
- [7] K. Kato: "Creep Response Calculation of Rubber-like Polymers using ADINA", *Computers and Structures*, Vol. 64, No. 5/6, pp.1013-1024, 1997.

TABLES & FIGURES



Figure 1 – The super-single drive (GMD) tyre, right, and the conventional dual tyres.

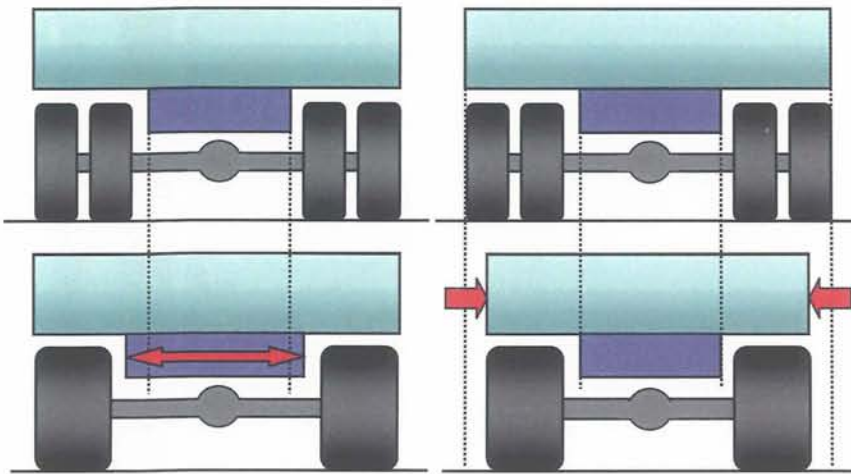
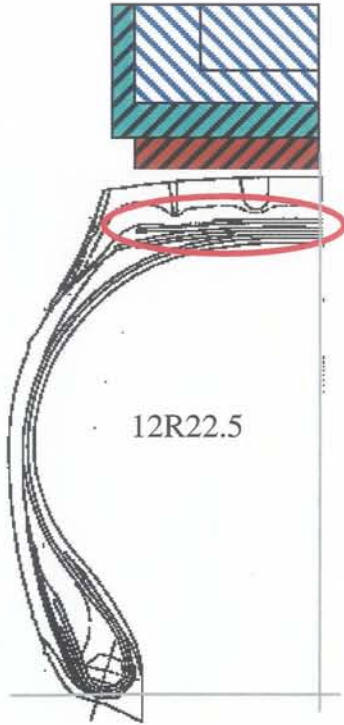

Figure 2 – Advantages of employing the GMD tyre in vehicle design.

CONVENTIONAL
BELT



WAVED (CURRENT)
BELT

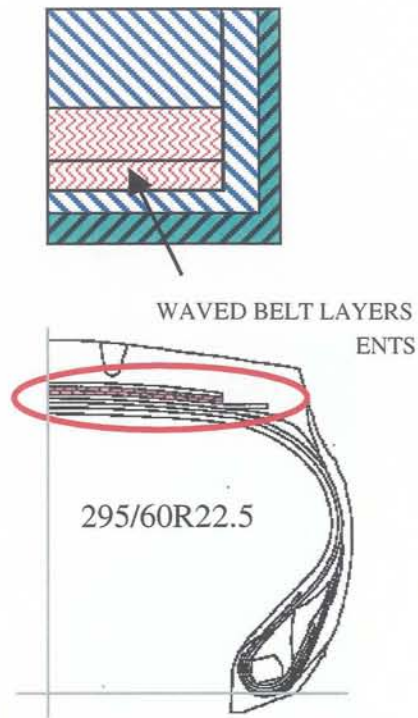

Figure 3 – Typical belt structures adapted to tyres for the truck and the bus.

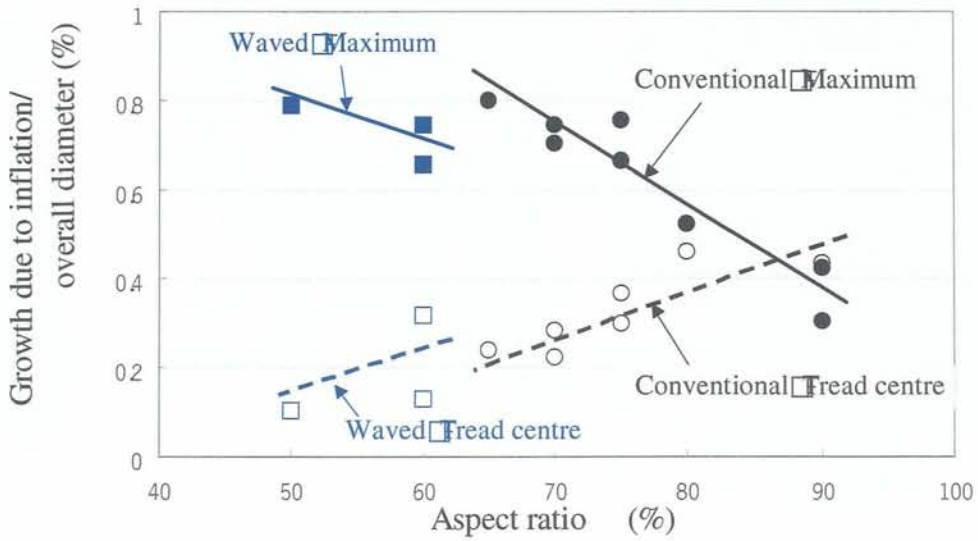

Figure 4 – Effect of the tyre aspect ratio on the tread growth by pressurisation.

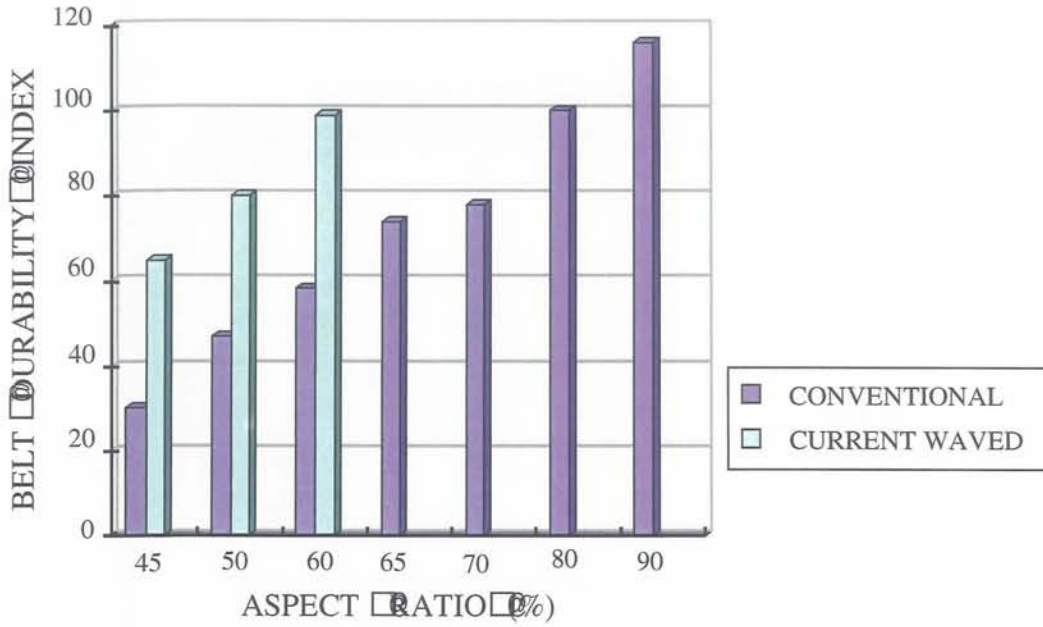

Figure 5 – Trend of the belt durability as a function of the aspect ratio.

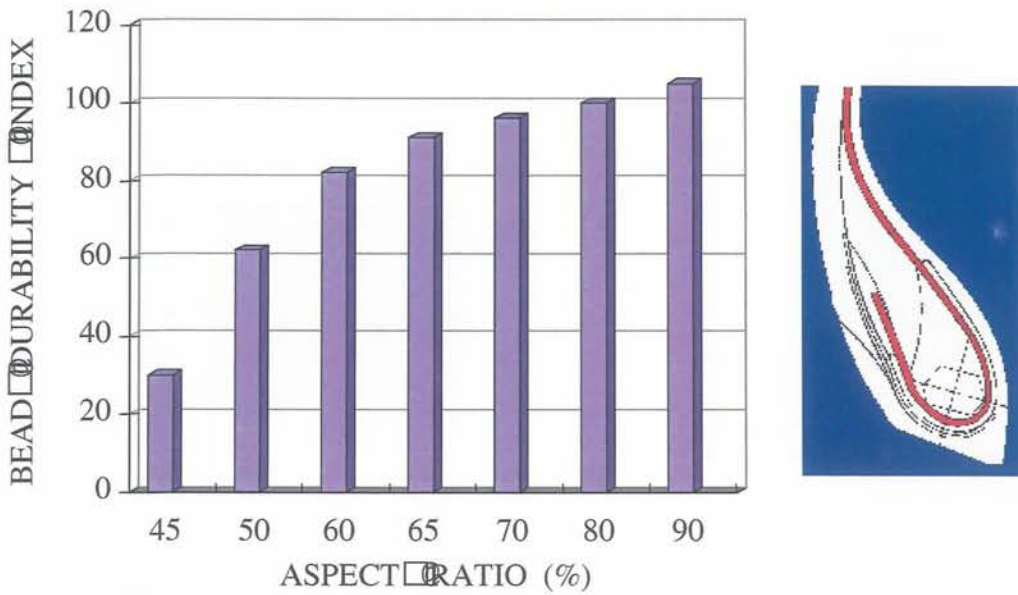

Figure 6 – Conventional bead structure, right, and trend of the durability as a function of the aspect ratio.

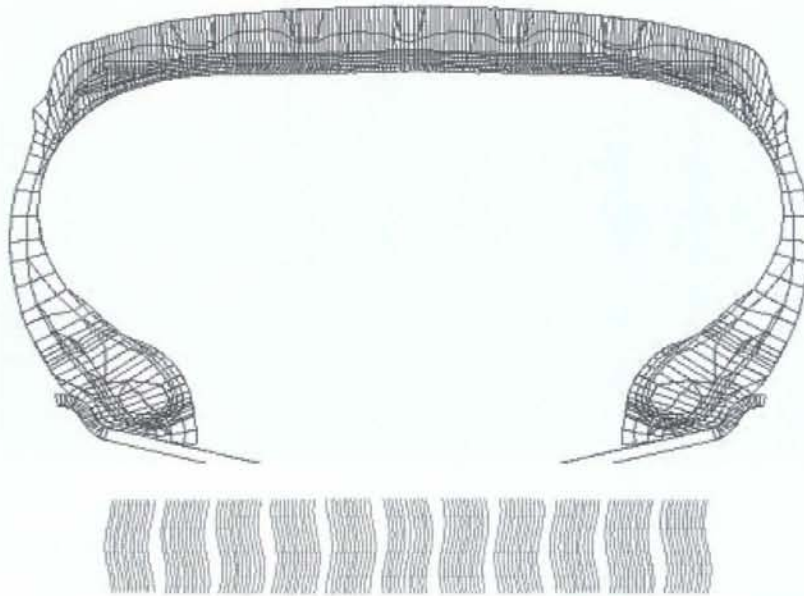

Figure 7 – Finite element mesh: a sectional view of the full three-dimensional FE model and a plane view of embedded WAVED cord bundles slightly out of phase each other.

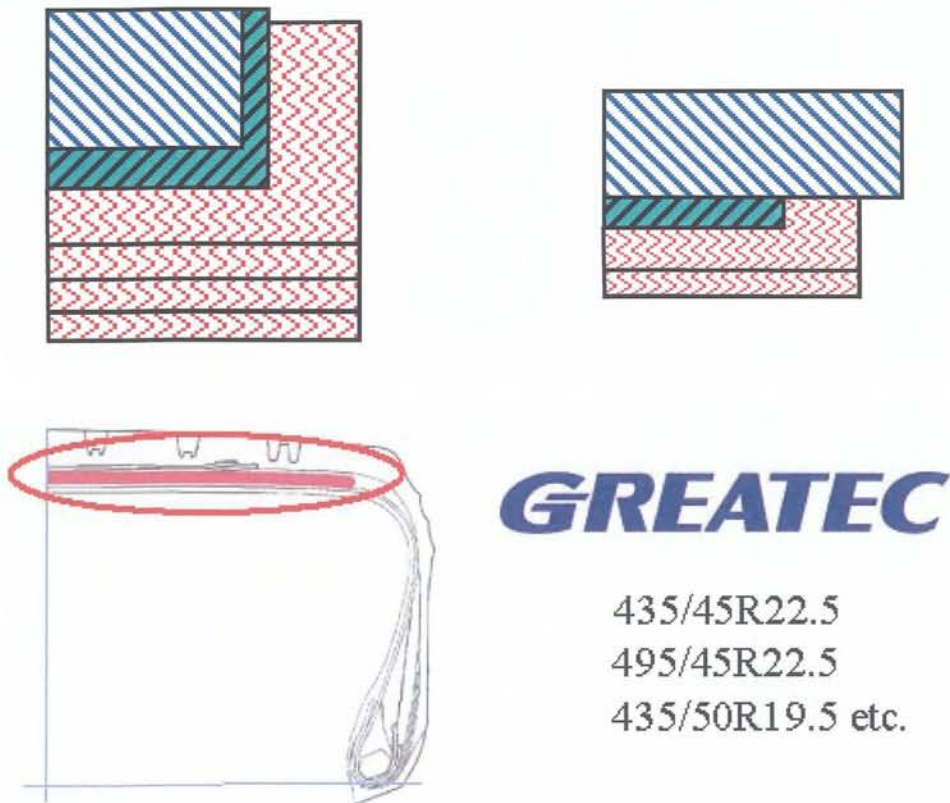

Figure 8 – Proposed belt package: the New WAVED belt.

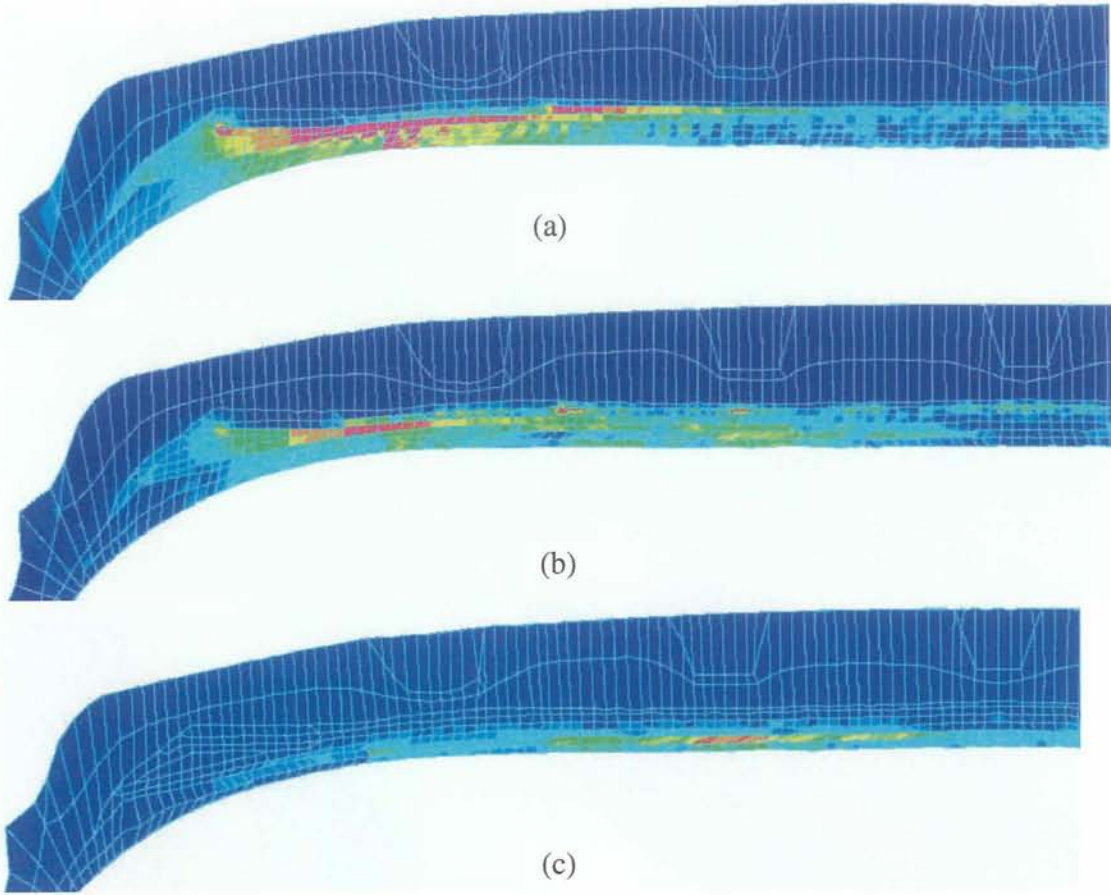

Figure 9 – Von Mises stress under pressurised condition: (a) the conventional belt, (b) the WAVED (current) belt, (c) the New WAVED belt.

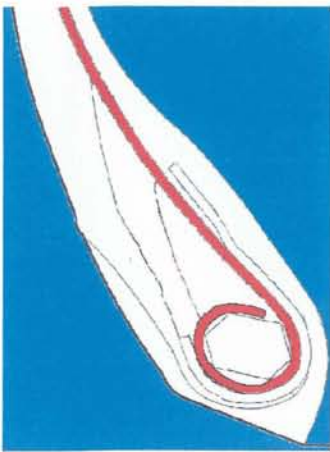
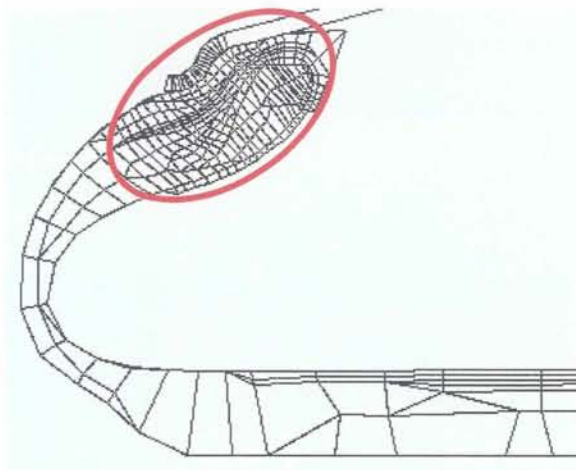
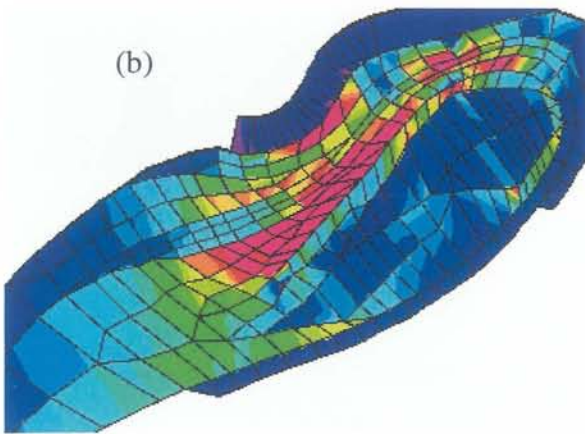

Figure 10 – An example of proposed bead structures: the TIP bead.



(a)



(b)

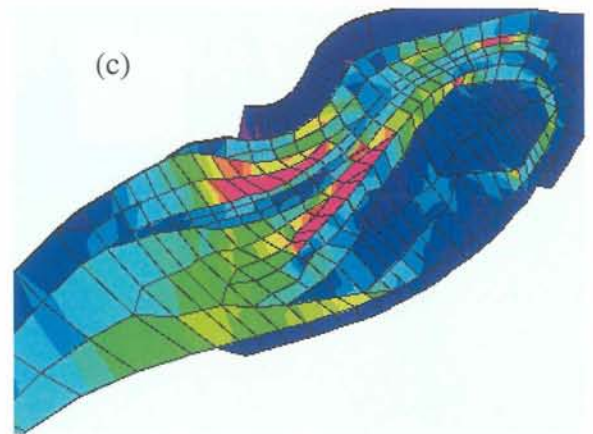

(c)

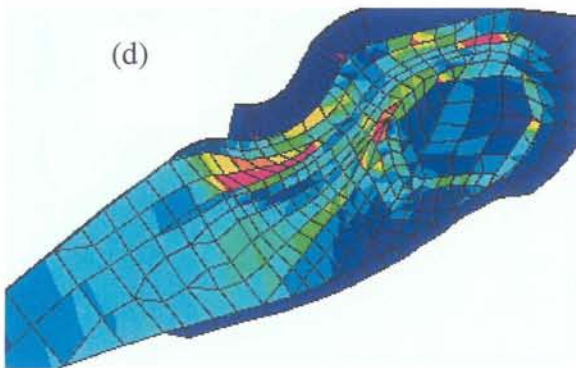

(d)

Figure 11 – Principal strain under loaded condition after thermal aging, 142 hours at 80 degrees Celsius: (a) deformed configuration in the right-under-the-load section, (b) the conventional bead, (c) the reinforced conventional-type bead, (d) the TIP bead.