

IMPROVING ABS ON HEAVY VEHICLES USING SLIP CONTROL

Kienhöfer, F.W., Cebon, D.

Cambridge University Engineering Department

Kienhöfer, F.W.

PhD Student

Cambridge University Engineering Department

CB2 1PZ

United Kingdom

fwk20@cam.ac.uk

ABSTRACT

This paper investigates the use of slip control on heavy vehicles to reduce stopping distance and compressed air usage in an emergency stop.

Conventional ABS reduces the cylinder brake pressure if wheel lock-up is predicted, and allows the cylinder brake pressure to increase once the wheel is back on the stable part of the mu-slip curve. This significantly increases the air usage and can increase the stopping distance. An alternative braking strategy, longitudinal slip control, is to measure the slip of the braked wheel and control the slip to its optimum point.

A hardware-in-the-loop (HiL) rig has been developed to investigate slip control. The hardware includes an air receiver, ABS or slip control modulator, brake cylinder and brake caliper. The braked wheel and vehicle dynamics are simulated on a micro-processor. The model includes road roughness and the suspension system dynamics, which have a significant effect on the braking performance.

A gain-scheduled slip controller using the same pneumatic actuation and valves as used by conventional ABS is developed. The slip control strategy is compared to the ABS strategy on the HiL rig and the initial results are very encouraging: on a smooth road the mean fully developed deceleration (MFDD) is increased by 6% and the air usage halved. The transient performance of the slip controller is at present very poor (rise-time of 1 s) as a result of the sluggish response of the ABS valves. This causes an approximate 10% increase in stopping distance.

Future work will investigate using more sophisticated control algorithms as well as an improved actuator to solve the poor transient response of the slip controller and reduce the stopping distance.

IMPROVING ABS ON HEAVY VEHICLES USING SLIP CONTROL

Kienhöfer, F.W., Cebon, D.

Cambridge University Engineering Department

MOTIVATION FOR IMPLEMENTING SLIP CONTROL

Improving the stopping distance of a vehicle helps to reduce collisions, casualties and damage to vehicles and goods. Field tests show that in a stopping event that activates the ABS (anti-lock braking system), the longitudinal slip varies from 0.05 to 1 (See Figure 1). The consequent periodic locking and unlocking motion increases the stopping distance. Slip control is an advance on the ABS algorithm, as the slip is measured and controlled to a point near to the “Maximum braking” point (illustrated by the blue circle in Figure 1).

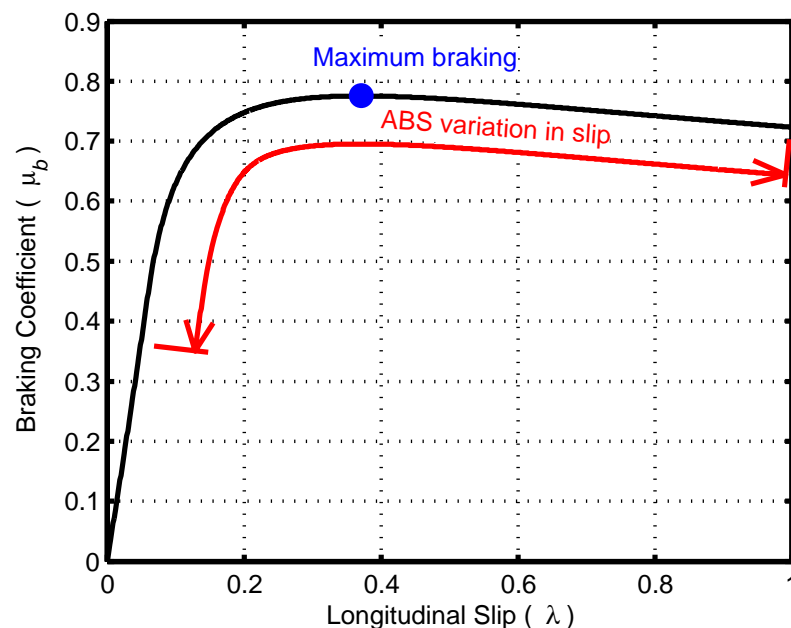

Figure 1 Braking coefficient (longitudinal tyre force / vertical tyre force) versus longitudinal slip

The basic ABS algorithm continuously releases the brake pressure only to later reapply the full brake pressure, once wheel lock-up has been prevented. This wastes compressed air. Because slip control makes only small adjustments to keep the wheel at the optimum slip point, it may be expected to reduce the compressed air consumption.

The continuous release and application of the brake pressure modulated by the ABS algorithm can detrimentally interact with the vertical vehicle dynamics (Hardy 1995). Slip control provides an opportunity for better integration with other vehicle control enhancements than ABS. These might include active semi-trailer steering (Jujnovich 2005) or active roll control (Roebuck 2005). Kimbrough (Kimbrough 1999) has proposed a theoretical framework for the implementation of combined braking and steering. Slip control is an integral element of the proposed strategy.

FIELD TESTING AND SIMULATION OF A CONVENTIONAL ABS SYSTEM

Before developing a slip controller, a comprehensive study and testing programme was conducted on a conventional ABS system. Field tests were performed on a 6-axle tractor/semi-trailer combination fitted with a Wabco Vario C ABS system. The tractor brakes were disabled and only the trailer brakes were activated. The initial speed was set to 12 m/s so that the trailer brakes would dissipate approximately the same amount of energy as they would under normal operation (assumed to be 22 m/s or 50 mph). Further details of the testing programme can be found in (Kienhöfer 2004). Results for an ABS stop on a medium friction surface ($\mu = 0.75$) are shown in Figure 2.

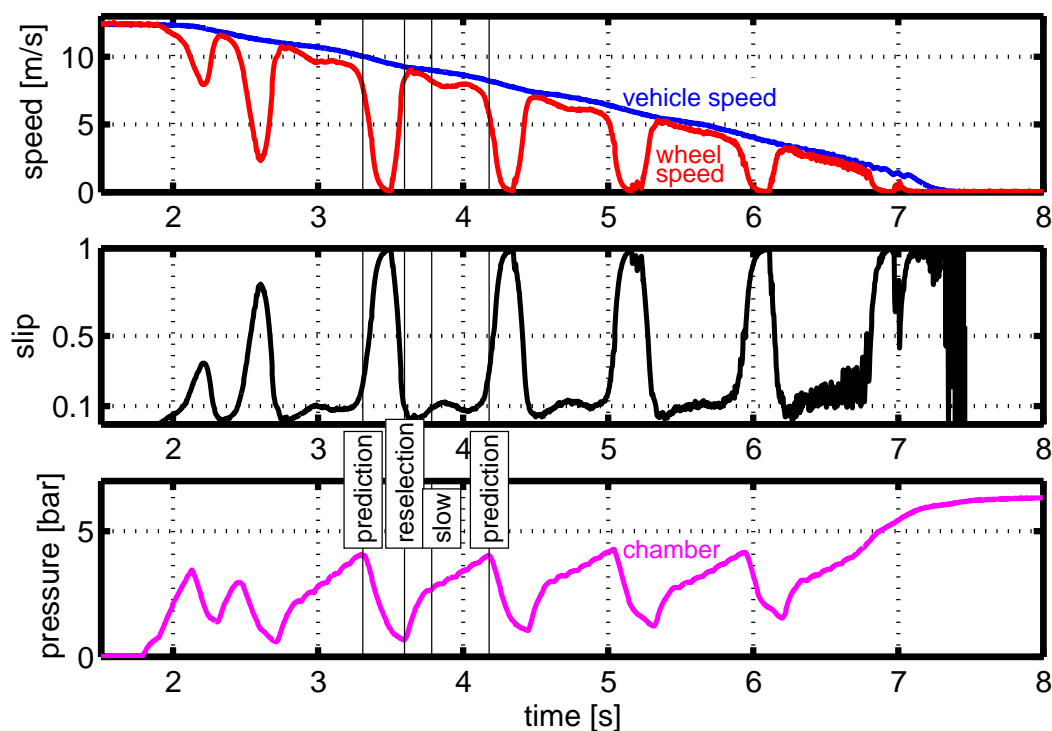

Figure 2 Field tests of an ABS stop on a medium friction surface ($\mu = 0.75$)

The top sub-plot presents the vehicle velocity in blue and the speed of the right-hand, rearmost trailer wheel in red. The middle subplot presents the longitudinal slip and the bottom subplot presents the brake chamber pressure attached to the same wheel.

In a typical ABS cycle, the wheel speed first begins to rapidly decrease (indicated by the first

vertical black line labelled “prediction” at approximately 3.3 s in Figure 2). The wheel deceleration exceeds the prediction threshold (around 20 m/s^2), the tyre saturates and the braking pressure is rapidly decreased. Because of the hysteresis and slow pneumatic response, the wheel still locks (slip=1) for a short period, but thereafter increases in speed. Thereafter, the “reselection” criterion is met. This typically requires the wheel acceleration to reach a peak and reduce again as indicated by the second vertical line. The ABS controller reacts by rapidly increasing the brake pressure so as to overcome hysteresis. This is followed by a phase in which the ABS controller slowly increases the braking pressure in short steps, as indicated by the third vertical line. The increase in pressure is required to ensure that the controller does not under-brake the wheel, while the retarded increase ensures that the braked wheel spends a longer time on the stable part of the mu-slip curve. Eventually the brake pressure is increased beyond what the tyre-road friction surface is able to produce, the prediction threshold is reached again and the ABS cycle resumes from the beginning. The cycle time is approximately one second.

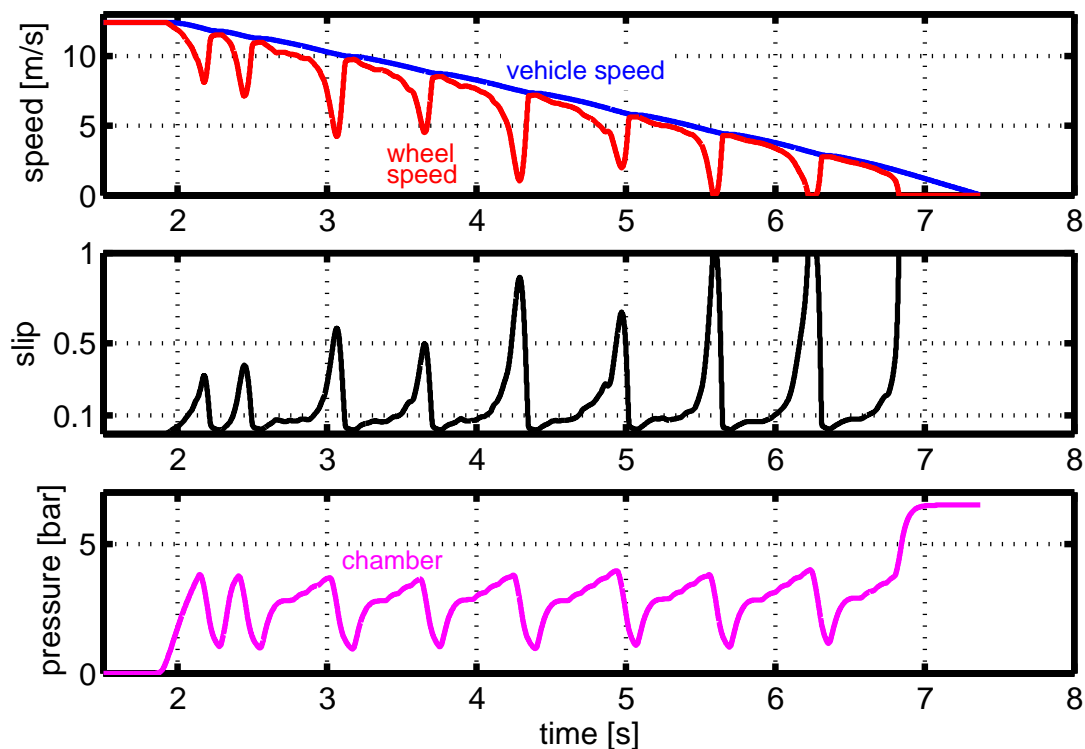

Figure 3 Simulation results of an ABS stop on a medium friction surface ($\mu = 0.75$)

A simulation model of the above field tests was developed so as to further understand the dynamics of braking and to allow for inexpensive, safe and quick analysis of alternative braking strategies. The quarter-car model contains four degrees of freedom: longitudinal motion of the vehicle, rotational motion of the braked wheel, and the vertical motion of the sprung and unsprung masses. Yaw and roll effects are excluded and the model is only valid for straight-line braking. The longitudinal load transfer due to quasi-static forward pitching motion of the trailer is accounted for. A semi-empirical tyre model (Fancher 1995) developed at the University of Michigan Transport Research Institute (UMTRI) is used to calculate the longitudinal tyre force.

Figure 3 presents simulation output for modelling the field tests shown in Figure 2. The road profile used for the simulation has an IRI (International Roughness Index) of 2.5 m/km, which is typical of a good paved road (Sayers 1986). The field test and simulation results show good agreement. The vehicle comes to rest at the same time, and the pressure pulses have a similar shape. A marked difference is that the simulated ABS cycles at a slightly higher frequency (1.5 Hz) compared to the field tests (just over 1 Hz). This difference is due in part to the exact details of the proprietary ABS algorithm being unknown and due to the approximations and simplifications of the transient pressure flows in the brake-lines.

HARDWARE-IN-THE-LOOP BRAKING RIG

A Hardware-in-the-Loop (HiL) braking test rig was developed so as to overcome the difficulties of simulating the exact details of proprietary ABS algorithms and the non-linear pneumatic flows in the brake-lines. A diagram illustrating the operation of the rig is shown in Figure 4.

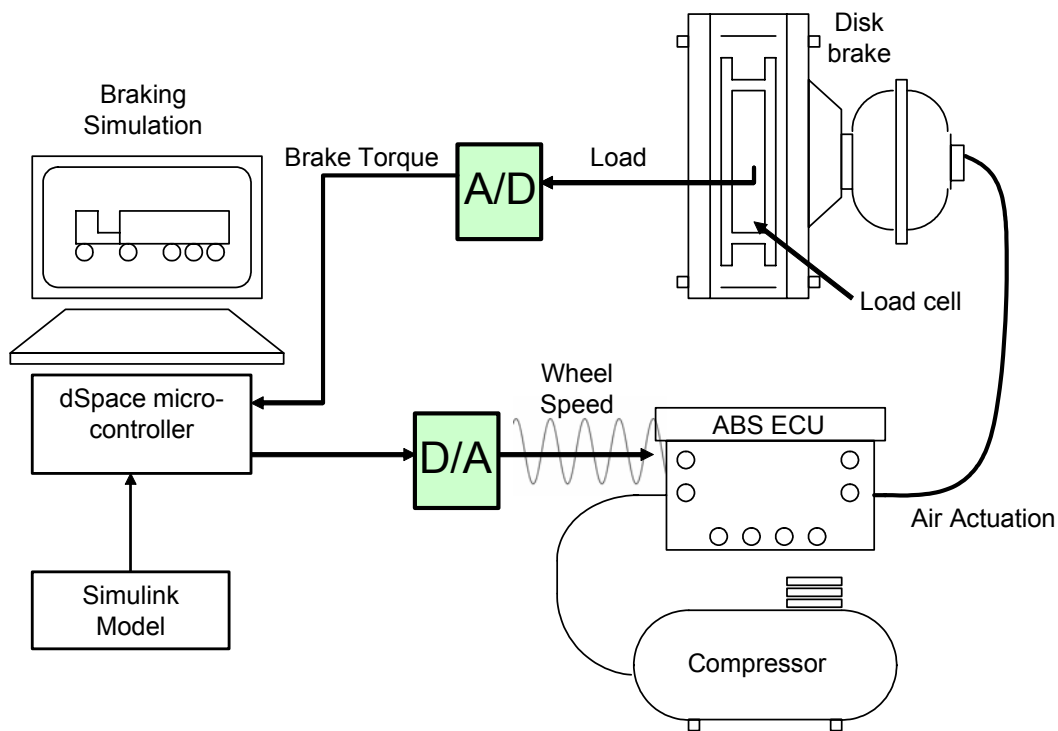

Figure 4 HiL braking rig layout

The hardware components of the rig include the ABS ECU (Haldex EB+), the brake actuator, the brake calliper and all the associated pneumatics. The calliper clamps a load cell. The measured force is used to calculate the brake torque. This torque brakes a vehicle model which is running in real time on a microprocessor. The vehicle simulation calculates the wheel speed and outputs a voltage to the ABS unit equivalent to the signals generated by the speed sensors on a real vehicle.

The HiL rig enables testing of slip control strategies in a safe, realistic environment. These

results can then be compared directly to the conventional ABS results, without requiring the exact details of the proprietary ABS algorithm to be known. Furthermore, there are no modelling inaccuracies for the difficult-to-model pneumatic components.

Results of a tractor-trailer combination conducting an ABS stop on asphalt ($\mu = 0.9$) from a speed of 22 m/s (50 mph) are illustrated in Figure 5. A road profile with an IRI of 2.5 m/km was used. The HiL results are qualitatively similar to the field test results presented in Figure 2 and the simulation results presented in Figure 3. It must be pointed out that a different frictional surface was used. Moreover, the ABS unit used in the HiL rig is different and is the latest generation technology from the braking company Haldex. The ABS algorithm appears to learn the surface type from the first two ABS cycles. Thereafter, the ABS unit tailors the pressure pulse increase to the surface type and thus reduces the magnitude and frequency of the pressure fluctuations.

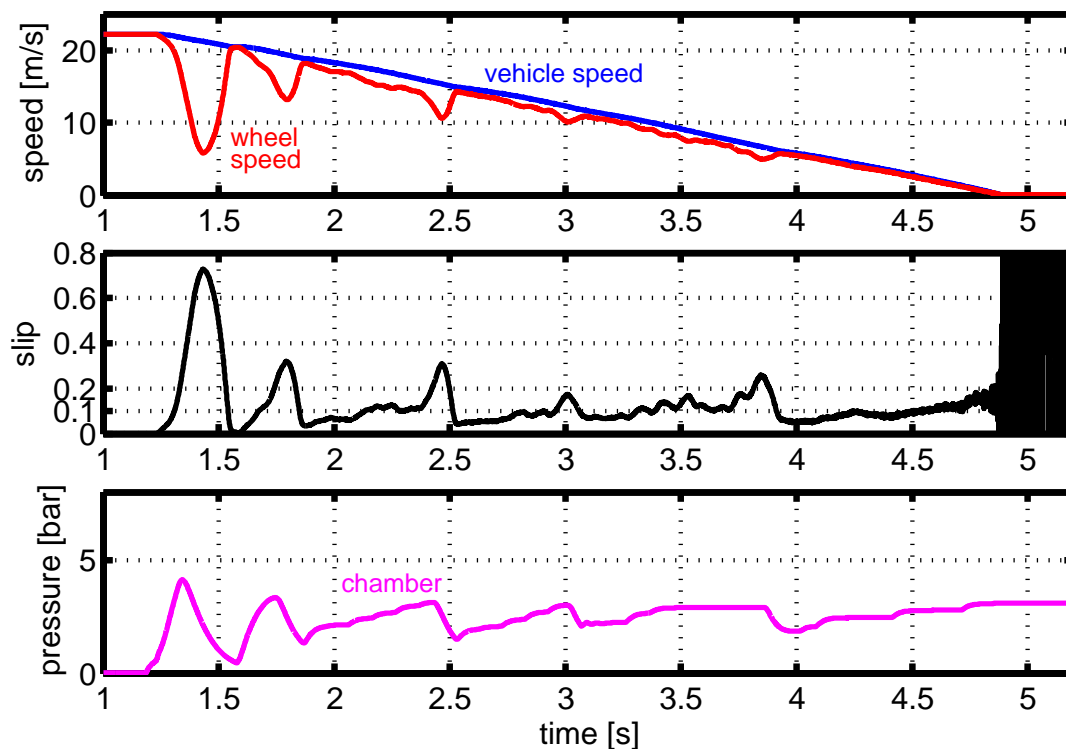

Figure 5 HiL results of an ABS stop on asphalt ($\mu = 0.9$)

THEORETICAL DEVELOPMENT OF A GAIN-SCHEDULED SLIP CONTROLLER

It would be ideal if slip control could be implemented using the same pneumatic actuation and valves as used by conventional ABS. This would save development costs and allow the system to fall back to a conventional ABS algorithm if a fault in the slip control was detected.

A mathematical model of the existing ABS system was developed, using measurements of key

properties from the HiL rig (pneumatic time delays, time constants etc) (Kienhöfer 2004). The model was used to design the slip controller. The derivation of key equations follows.

The longitudinal dynamics of the vehicle system are given by:

$$F_x - m\dot{v}_x = 0 \quad (1)$$

where F_x = the braking force at the tyre-road interface of the controlled wheel,
 m = the proportion of the total vehicle mass braked by the wheel, and
 v_x = longitudinal velocity of the vehicle.

Rotational motion of the wheel is governed by:

$$\frac{J\dot{\omega}}{r_r} + rF_x + T_B = 0 \quad (2)$$

where J = the moment of inertia of the wheel,
 ω = the rotational velocity of the wheel,
 r_r = the rolling radius of the wheel, and
 T_B = the brake torque.

The tyre response can be linearised at a specified slip value:

$$-\Delta F_x = C_\lambda \Delta \lambda \quad (3)$$

where ΔF_x = the change braking force,
 C_λ = tyre stiffness at a specified slip value, and
 $\Delta \lambda$ = the change in slip.

The braking torque is assumed to be proportional to the pressure in the brake chamber and brake fade is ignored since the focus is on a single emergency stop:

$$T_B = 2A_c P_c \mu_{br} r_{br} \quad (4)$$

where A_c = the effective area of the brake chamber diaphragm,
 P_c = the brake chamber pressure,
 μ_{br} = the coefficient of friction between the brake disk and brake pads, and
 r_{br} = the effective radius through which the disk and brake pad friction acts.

The transfer function of the brake demand pressure to the pressure in the brake chamber is approximated as a first order system with time delay:

$$P_c = \frac{P_d}{1 + \tau s} e^{-sT_d} \quad (5)$$

where P_d = the brake demand pressure,
 τ = time constant characterising the transient response of the valves, and
 T_d = the time delay which includes the time for the valves to react and the brake

pressure to travel from the ABS unit to the brake chamber.

Combining equations (1-5) gives the required transfer function:

$$\frac{\Delta\lambda}{\Delta P_d}(s) = \frac{e^{-sT_d}}{1 + \tau s} 2A_c \mu_{br} r_{br} \frac{r_r}{v_x J s + C_\lambda r_r r} \quad (6)$$

Because the plant dynamics change with varying vehicle speed, a gain-scheduled controller (Solyom 2004) has been implemented (See Figure 6). The controller for each speed has been designed using loop-shaping of the transfer function in equation (6) to ensure satisfactory gain and phase margins.

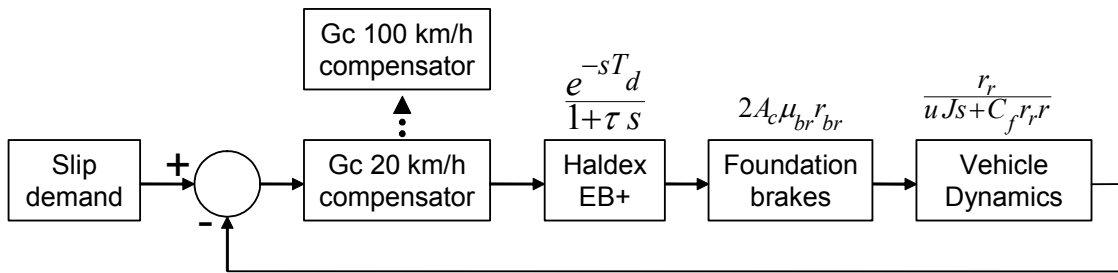

Figure 6 Block diagram of gain scheduled controller

HIL TESTING OF SLIP CONTROL USING EXISTING ABS VALVES

The following section presents HiL results of implementing the gain-scheduled slip controller developed above. The slip demand has been set to 0.1 and not the “Maximum braking” point (See Figure 1). A slip demand of 0.1 is close to the “Maximum braking” point and allows for easier control as the open-loop transfer function is stable. This results in the controller having less work to do and as a result less compressed air is used. A slip demand of 0.1 has been used by (Solyom 2004).

Figure 7 presents results of the designed slip controller tested on the HiL rig, with the same vehicle parameters and road surface used to test the ABS controller in Figure 5. Comparing the brake pressure variation measured in the brake chamber it is clear that the slip controller in Figure 7 has reduced the large slip variations compared to the conventional ABS in Figure 5 (especially during the first two ABS cycles). The transient response of the slip controller is, however, very sluggish with an approximate rise time of 1 s. This is caused by the sluggish response of the pneumatic valves (30 ms time delay in actuation) in concert with the dynamic response of the control loop. The controller gains cannot be increased to improve the transient response because this causes instability.

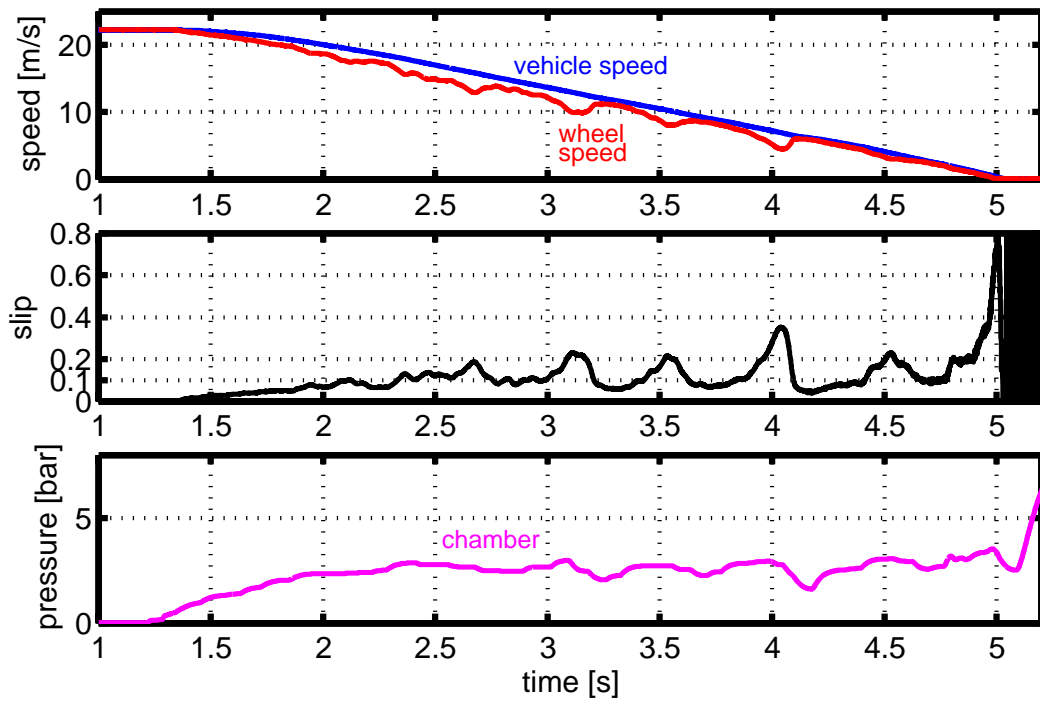

Figure 7 HiL results of an emergency stop on asphalt ($\mu = 0.9$) using slip control

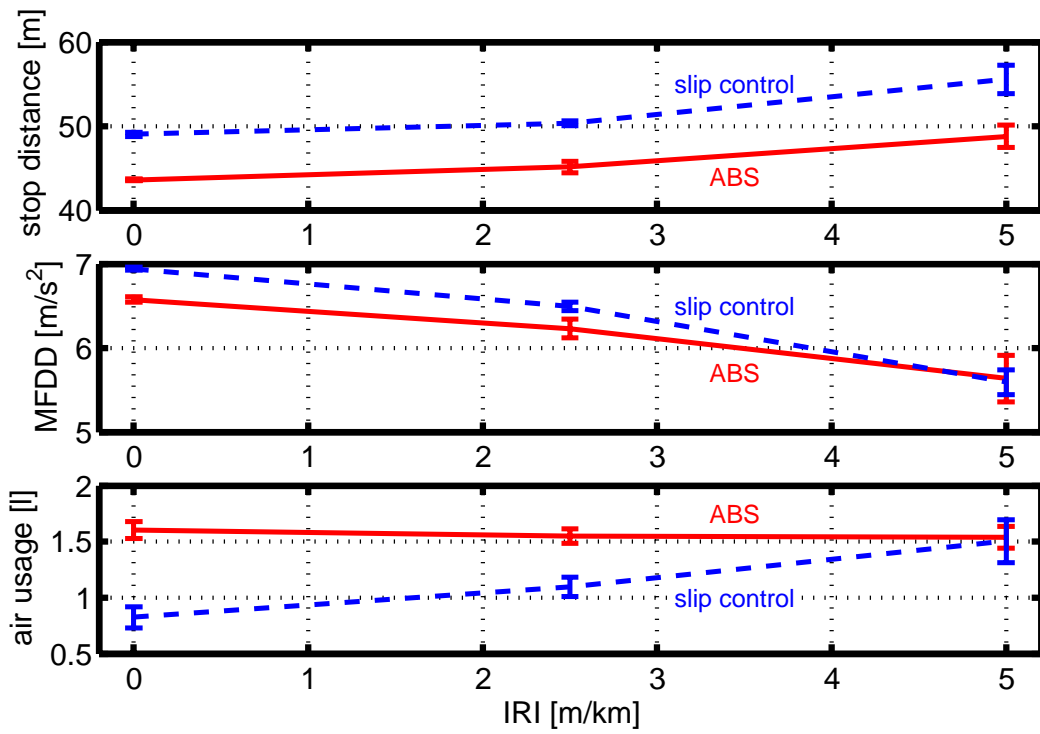

Figure 8 Comparison of ABS versus slip control

Figure 8 presents a comparison of ABS and slip control testing on the HiL rig. The top subplot presents the stopping distance, the middle subplot shows the mean fully developed deceleration (MFDD - the average deceleration from 80% of the initial vehicle speed to 10% of the initial vehicle speed) and the bottom subplot shows the air usage.

The slip control strategy results in an approximate 10% increase in stopping distance, for the three IRI values considered. This increase is due to the poor transient response of the slip controller (rise time of 1 s in Figure 7). The target slip level takes longer to build up and the poor deceleration at the beginning of the stopping event severely penalises the stopping distance because at this time the speed is at its highest. The stopping distance of both strategies increases as the road roughness or IRI increases.

On the smooth road, IRI=0 m/km, the MFDD is slightly higher for the slip control than the ABS (approximately 6%). On the rough road, IRI=5 m/km, the MFDD values for the two controllers are almost the same.

On the smooth surface (IRI = 0 m/km), the slip control strategy uses 0.8 litres of compressed air as compared to the ABS strategy which uses 1.6 litres, which is a substantial reduction. On the IRI = 2.5 m/km surface the slip control strategy uses 1.1 litres while the ABS strategy uses 1.6 litres and on the rough IRI = 5 m/km surface the slip control and ABS strategy both use 1.5 litres.

CONCLUSIONS

- (i) A simulation model and HiL rig have been developed and validated with field tests.
- (ii) The theory of a gain-scheduled slip controller using the ABS valves was developed.
- (iii) The slip control strategy was compared to the ABS strategy on the HiL rig and the initial results were very encouraging: on the smooth road the mean fully developed deceleration (MFDD) was increased by 6% and the compressed air usage halved.
- (iv) The transient performance of the slip controller was very poor (rise-time of 1 s) as a result of the sluggish response of the ABS valves. This results in an approximate 10% increase in stopping distance.
- (v) Future work will investigate algorithms to estimate the optimal slip point in real time; use of more sophisticated control algorithms, particularly to improve the poor transient response of the slip controller and consequently reduce the stopping distance as well as the balance between stopping performance and air usage.

ACKNOWLEDGEMENTS

The authors would like to thank the members of the Cambridge Vehicle Dynamics Consortium (CVDC), Cambridge Commonwealth Trust, University of the Witwatersrand, and Churchill College for their parts in funding this work. At the time of writing, the Cambridge Vehicle Dynamics Consortium has the following industrial members: ArvinMeritor, Bridgestone Tyres, Camcon, Denby Transport, Firestone Industrial Products, Fluid Power Design, FM Engineering, Fruehauf, Haldex, Mektronika Systems, MIRA, QinetiQ, Shell UK, Tinsley Bridge, and Volvo Trucks.

Thanks also to Richard Roebuck, Arnaud Miège, Edd Stone, Brian Jujnovich, Andrew Odhams, Marco Costanzi, Charlie Cheng and the technicians of the Mechanics Lab of CUED for the contributions and help.

REFERENCES

- Fancher, P. S. (1995). Generic Data for Representing Truck Tire Characteristics in Simulations of a Braking and Braking-in-a-Turn Maneuvers, University of Michigan Transport Research Institute (UMTRI).
- Hardy, M. S., and Cebon, D. (1995). "An Investigation of Anti-lock Braking Strategies for Heavy Goods Vehicles." Proceedings of the Institution of Mechanical Engineers, Part D: Journal of Automobile Engineering **209**(4): 263-271.
- Jujnovich, B. (2005). Active Steering of Articulated Vehicles. Cambridge University Engineering Department. Cambridge, University of Cambridge. **PhD**.
- Kienhöfer, F., and Cebon, D. (2004). An Investigation of ABS Strategies for Articulated Vehicles. 8th International Symposium on Heavy Vehicles Weights and Dimensions, Midrand, South Africa.
- Kimbrough, S. (1999). "A Topology for Vehicle Stability and Handling Enhancement Via Wheel slip Control." American Society of Mechanical Engineers, Design Engineering Division (Publication) DE **101**: 115-124.
- Roebuck, R. L., Cebon, D., Jeppesen, B.P., Haque, J. (2005). "A systems approach to controlled heavy vehicle suspensions." International Journal of Heavy Vehicle Systems **12**(3): 169-192.
- Sayers, M. W., Gillespie, T.D., Paterson, D.O. (1986). Guidelines for Conducting and Calibrating Road Roughness Measurements, University of Michigan Transport Research Institute (UMTRI).
- Solyom, S., Rantzer, A., Lüdemann, J. (2004). "Synthesis of a Model-based Tire Slip Controller." Vehicle System Dynamics **41**(6): 477-511.