

A RESEARCH ON MIXED PULSE CONVERTER TURBOCHARGING SYSTEM

Shiyou Yang¹, Lin-Shu Wang², Hongzhong Gu³, Kangyao Deng³ and Yi Cui³

1 Department of Mechanical Engineering, University of Wisconsin at Madison, Madison, WI
53706, U.S.A, shiyou_yang@hotmail.com

2 Department of Mechanical Engineering, SUNY-Stony Brook, Stony Brook, NY 11794-2300,
U.S.A

3 School of Mechanical Engineering, Shanghai Jiaotong University, Shanghai 200030, PR China

Abstract: A newly developed turbocharging system, named MIXPC, is proposed and the performance of the proposed system applied to diesel engines is evaluated. The aim of this proposed system is to reduce the scavenging interference between cylinders, and to lower the pumping loss in cylinders and the brake specific fuel consumption. In addition, exhaust manifolds of simplified design can be constructed with small dimensions, low weight and a single turbine entry. By simulating a 16V280ZJG diesel engine using the MPC turbocharging system and MIXPC, it is found that not only the average scavenging coefficient of MIXPC is larger than that of MPC, but also cylinders of MIXPC have more homogeneous scavenging coefficients than that of MPC, and the pumping loss and BSFC of MIXPC are lower than that of MPC. To validate the prediction results, experiments of a 16V280ZJG diesel engine equipped with MIXPC have been successfully finished. Experiment results show that the MIXPC turbocharging system reduces the exhaust gas temperature before turbine and BSFC at part load, and the exhaust gas temperatures at each cylinder outlet at high load are more uniform. The resulting lower thermal load suggests that the diesel engine equipped with MIXPC has the potential to increase its power.

A RESEARCH ON MIXED PULSE CONVERTER TURBOCHARGING SYSTEM

Shiyou Yang¹, Lin-Shu Wang², Hongzhong Gu³, Kangyao Deng³ and Yi Cui³

1 Department of Mechanical Engineering, University of Wisconsin at Madison, Madison, WI
53706, U.S.A, shiyou_yang@hotmail.com

2 Department of Mechanical Engineering, SUNY-Stony Brook, Stony Brook, NY 11794-2300,
U.S.A

3 School of Mechanical Engineering, Shanghai Jiaotong University, Shanghai 200030, PR China

Abstract: A newly developed turbocharging system, named MIXPC, is proposed and the performance of the proposed system applied to diesel engines is evaluated. The aim of this proposed system is to reduce the scavenging interference between cylinders, and to lower the pumping loss in cylinders and the brake specific fuel consumption. In addition, exhaust manifolds of simplified design can be constructed with small dimensions, low weight and a single turbine entry. By simulating a 16V280ZJG diesel engine using the MPC turbocharging system and MIXPC, it is found that not only the average scavenging coefficient of MIXPC is larger than that of MPC, but also cylinders of MIXPC have more homogeneous scavenging coefficients than that of MPC, and the pumping loss and BSFC of MIXPC are lower than that of MPC. To validate the prediction results, experiments of a 16V280ZJG diesel engine equipped with MIXPC have been successfully finished. Experiment results show that the MIXPC turbocharging system reduces the exhaust gas temperature before turbine and BSFC at part load, and the exhaust gas temperatures at each cylinder outlet at high load are more uniform. The resulting lower thermal load suggests that the diesel engine equipped with MIXPC has the potential to increase its power.

NOTATION

P_{\max}	Maximum cylinder pressure, MPa	φ_{sm}	Mean scavenging coefficient
b_e	Brake specific fuel consumption, g/(kW·h)	W_{pump}	Pumping loss, kg·m
η_v	Volumetric efficiency	P_e	Brake mean effective cylinder pressure, MPa
α	Excess combustion air ratio	Δt_{\max}	Maximum difference of the exhaust gas temperature at each cylinder outlet, °C

P_s	Boosted air pressure, MPa	T_r	Exhaust gas temperature at cylinder outlet, °C
T_s	Boosted air temperature, K	G_s	Mass flow rate, kg/s
T_T	Gas temperature before turbine, °C	φ_{s1-8}	Scavenging coefficient of each cylinder

1. INTRODUCTION

Internal combustion engine turbocharging is used for power boosting. In the design of turbocharged internal combustion engines the selection of the most effective exhaust configurations of turbocharging system is of paramount importance since engine performances are greatly affected by the gas flow unsteadiness. Four different systems are generally adopted: the constant pressure turbocharging system, the pulse turbocharging system, the pulse converter turbocharging system and the MPC (modular pulse converter) turbocharging system [1]. In the constant pressure turbocharging system the exhaust gases coming from all cylinders flow into a common exhaust manifold, whose volume is sufficiently large to damp down the unsteady flow, and then feed one single-entry turbine. The fluctuating gas flow [2, 3] from the cylinders is damped so that the conditions at the turbine entry are essentially steady with time, providing a nearly constant pressure turbocharging. As the mass flow is relatively constant, high efficiency of the turbine is achieved. The disadvantage of this kind of turbocharging system is that little of high kinetic energy of the exhaust gases leaving the cylinders is utilized. The frictional losses, due to the mixing process between exhaust flows, coming from different cylinders, decrease the available energy. The part load performances and transient responses of this kind of turbocharging system are rather poor, too. A better utilization of the exhaust kinetic energy can be obtained by adopting the pulse turbocharging system [4, 5], in which the available energy at the turbine is greater than the constant pressure turbocharging system architecture. However, the turbine efficiency is lower because the gas flow into the turbine is highly unsteady and the turbine operates under variable conditions. The flow unsteadiness in the pulse turbocharging system can be reduced by grouping together several cylinders in a common exhaust pipe, which is then connected to a pulse converter. This kind of turbocharging is called the pulse converter (PC) turbocharging system. The disadvantage of this kind of turbocharging system is that the structure of the exhaust manifolds is complicated [1]. In the last decade the MPC turbocharging system became popular because of its simpler structure and convenience of production. The drawback of the MPC turbocharging system is that the scavenging interference often occurs at any two of the first four cylinders near the closed end of the exhaust manifold. Thus, the amount of the scavenging air of each cylinder is discrepant. This discrepancy will cause a large difference of the exhaust gas temperatures at each cylinder outlet.

In order to overcome the disadvantages of the above four typical turbocharging systems, a new turbocharging system is proposed. The proposed technology, named mixed pulse converter (MIXPC) turbocharging system, can be used for 4 to 20 cylinders diesel engines. Simulations and experiments of the MIXPC turbocharging system applied for turbocharged diesel engines

have been finished. For the simulation study, the authors developed an engine performance simulation code, in which a second-order FVM+TVD method is used to simulate the one-dimensional unsteady gas dynamic phenomenon in intake and exhaust pipe systems.

2. THE PRINCIPLE AND CHARACTERISTICS OF THE MIXPC TURBOCHARGING SYSTEM

For convenience, an 8-cylinder diesel engine is used as an example. Four types of MIXPC are shown in figure 1. The exhaust manifold of the four cylinders (5~8) near the turbine is constructed in MPC style; the exhaust manifold of the four cylinders (1~4) near the closed end of the exhaust manifold is constructed in pulse converter style. The exhaust pipes from cylinder No. 1 to No. 4 are separated into 2 groups of pipes, according to different firing orders. The criterion for selecting an optimum exhaust manifold arrangement among the types from Figure 1 is that the scavenging interference of the two cylinders in the same group of pipes should be avoided.

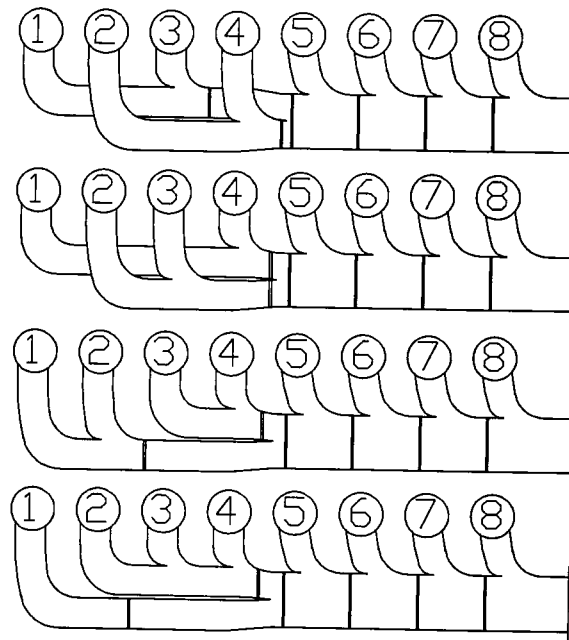
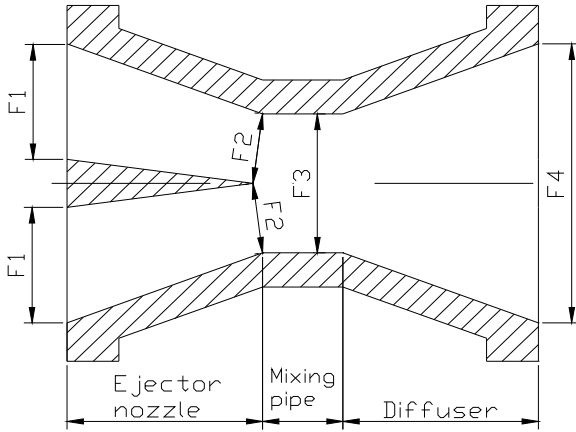

Figure 1. MIXPC for 8-cylinder in-line diesel engines.

Figure 2 shows the pulse converter in the pulse converter (PC) turbocharging system. In this system, the volume of the mixing pipe before the turbine is small and the length short. The pressure wave in the mixing pipe coming from one group of pipes will be transmitted to the other group of pipes, and then influences the scavenging process of the cylinders connected to that group of pipes. Hence it is necessary that the area ratio of the pulse converter is generally less than 1. The ejector nozzle's area ratio is generally 0.65~0.85, and the throat's area ratio is generally 0.5~1.0 [1]. Figure 3 shows the pulse converter in the MIXPC turbocharging system. From figure 3, it is seen that there is no area reduction necessary in the pulse converter for the

following reason: In the MIXPC turbocharging system, after the pulse converter, the MPC type exhaust manifolds of 4 cylinders are followed. Because of their larger volume and greater length, reflection of the pressure wave is decreased. Therefore the scavenging interference is small even without any area reduction in the pulse converter.



Ejector nozzle's area ratio= $F2/F1$
Throat's area ratio= $F3/F4$

Figure 2. The pulse converter in the pulse converter (PC) turbocharging system.

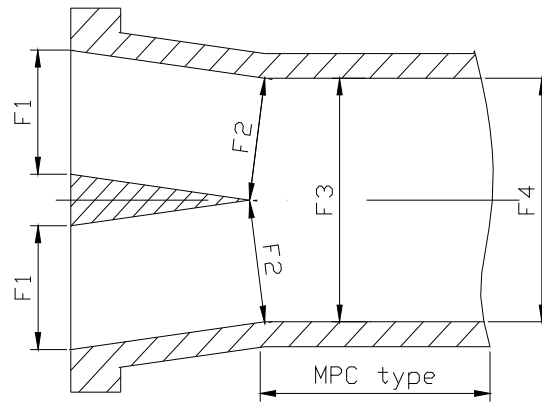

$F2/F1=1, F4/F3=1$

Figure 3. The pulse converter in the MIXPC turbocharging system.

Figure 4 shows the exhaust manifold of the MPC turbocharging system, which shows the typical reduction in its throat area. Figure 5 shows the MPC type exhaust manifold of the MIXPC turbocharging system. For the MPC type exhaust manifold from cylinder No. 5 to No. 8 in the MIXPC turbocharging system, the throat's area reduction (A_T/A_1) of the branch exhaust pipe is also unnecessary, because the four cylinders near the turbine are located at the downstream of the exhaust system, and the velocity of the exhaust gas is larger. Therefore the MPC type exhaust manifold of the MIXPC turbocharging system is different with the exhaust manifold of the MPC turbocharging system. Actually, in the MPC turbocharging system, the scavenging interference of the last four cylinders is also small. So the throat's area reduction of the branch exhaust pipe of the last four cylinders would also be unnecessary in the MPC turbocharging system. However the throat's area reduction of the branch exhaust pipe from cylinder No. 1 to No. 4 in the MPC turbocharging system is necessary. In the MPC turbocharging system, the exhaust manifold of cylinders No. 5 to No.8 is made in the same design as that of cylinders No. 1 to No. 4 (with the throat's area reduction of branch exhaust pipe) for the convenience of modular construction.

Compared with the MPC turbocharging system, the MIXPC turbocharging system has no nozzle's or throat's area reduction anywhere. Therefore, the pumping loss in cylinders is smaller, and the transmission of energy from the cylinders to the turbine is more efficient, and thus, the fuel economy of diesel engines with MIXPC is better. Figure 6 recapitulates the development of turbocharging systems. The turbine efficiency of the first generation pulse turbocharging system

(with four exhaust pipes, four turbine entries for each turbine and one pulse in each exhaust pipe) is low. Then the pulse turbocharging system was developed into the pulse converter turbocharging system with two turbine entries. In the pulse converter turbocharging system, there exists nozzle's or throat's area reduction, which causes a larger loss of fluid available energy. But since the turbine efficiency is higher, the overall engine performances are improved. As a result, the pulse converter turbocharging system became used widely. However, the construction of the exhaust manifold of PC system is complicated.

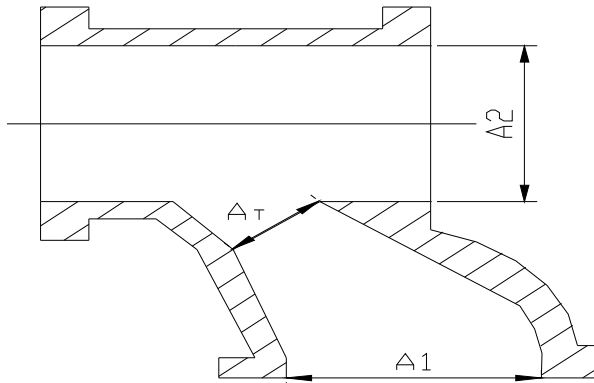

$$A_T/A1 < 1$$

Figure 4. The exhaust manifold of the MPC turbocharging system.

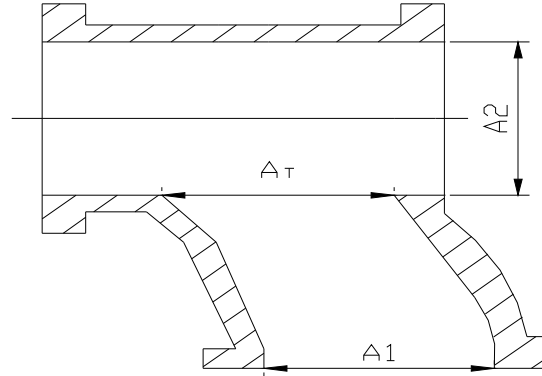

$$A_T/A1 = 1 \text{ or } > 1$$

Figure 5. The MPC type exhaust manifold of the MIXPC turbocharging system.

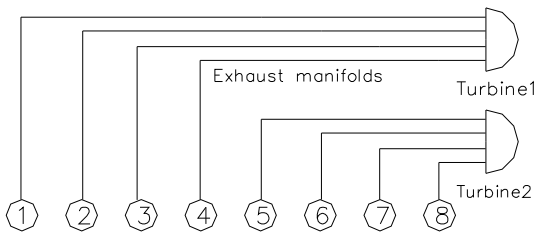

(a) The pulse turbocharging system

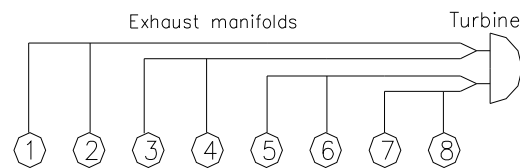

(b) The pulse converter turbocharging system

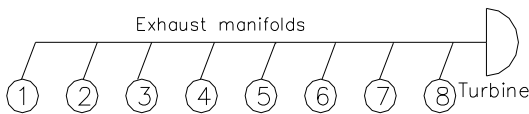

(c) The MPC turbocharging system

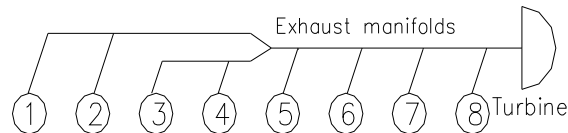

(d) The MIXPC turbocharging system

Figure 6. The development of turbocharging systems.

One solution to address this shortcoming the MPC turbocharging system was developed in recent decades. At this stage, the construction of the exhaust manifold is simpler, and it is easy to realize the series production. Two drawbacks remain: Since the outlet of the branch exhaust pipe

of each cylinder has a throat area reduction, the pumping loss in cylinders is larger; In addition, there exists scavenging interference in the MPC turbocharging system. To overcome the drawbacks of the above four typical turbocharging systems, the MIXPC turbocharging system is developed as a better solution. There is no throat's or nozzle's area reduction in exhaust manifolds, so the pumping loss in cylinders is smaller. The scavenging interference can be overcome, and the exhaust manifold is simpler because the turbine has only one entry. The turbine efficiency is higher and BSFC can be decreased. Furthermore, the MIXPC turbocharging system can be easily used in the STC (sequential turbocharging) and VGT (variable geometry turbocharger) systems. Therefore, the MIXPC turbocharging system is a leap forward in the development of turbocharging systems.

3. SIMULATIONS OF DIESEL ENGINES USING THE MIXPC TURBOCHARGING SYSTEM

For simulating the performances of turbocharged diesel engines using the MIXPC turbocharging system, an engine performance simulation code, in which a second-order FVM+TVD (finite volume method + total variation diminishing) method is used to simulate the one-dimensional unsteady gas dynamic phenomenon in intake and exhaust pipe systems, has been developed. Under the restriction of the length of this paper, the detail of this method will not be presented in detail at here. However, good agreements of calculated results with measured results, as well as with theoretical results, demonstrate that the code can be effectively used to simulate performances of internal combustion engines.

In order to validate the idea of MIXPC, a 16V280ZJG turbocharged inter-cooled rail use diesel engine is used as an example. The MPC turbocharging system originally used on the 16V280ZJG diesel engine has large scavenging interference. The large scavenging interference causes a large variation in the exhaust gas temperatures at each cylinder outlet. At full load the maximum difference of the exhaust gas temperature at each cylinder outlet exceeds 150°C. Such a high temperature difference limits the potential of increasing the engine's power. To reduce temperature variation leading to the potential for power increase, the MIXPC turbocharging system is used. The assembly drawing of MIXPC designed for this engine is shown in figure 7. In the structure, the diameter of the branch exhaust pipe of each cylinder changes from 110 mm to 120 mm, and the diameter of the exhaust manifold is 160 mm.

To investigate the scavenging interference of a turbocharged diesel engine using different turbocharging systems, a scavenging coefficient is introduced here, which is defined as the ratio of the charge mass flowing through intake valves of a cylinder in one cycle to the mass remaining in this cylinder at intake valve closing. So the scavenging coefficient can be used to evaluate whether or not the scavenging process of a cylinder is good. The larger and more uniform is the scavenging coefficient of each cylinder, the better is the scavenging effect.

There are 15 possible firing orders for V16 diesel engines. Performance simulations have been carried out for every firing order which can be used for the 16V280ZJG diesel engine using the MIXPC turbocharging system. The simulation comparison of the rail propulsion performances between MIXPC and MPC is shown in table 1.

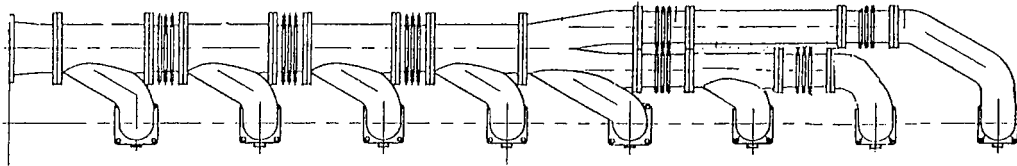

Figure 7. The assembly drawing of the MIXPC turbocharging system.

Table 1. Simulation comparison of performances between the MIXPC and MPC.

Load %	MIXPC		MPC		Load %	MIXPC		MPC	
	100	56	100	56		100	56	100	56
φ_{s1}	1.146	1.203	1.120	1.192	φ_{sm}	1.140	1.175	1.083	1.102
φ_{s2}	1.214	1.319	1.038	1.024	b_e	203.1	211.2	207.4	215.1
φ_{s3}	1.127	1.151	1.113	1.127	η_v	1.042	1.050	1.037	1.034
φ_{s4}	1.081	1.176	1.045	1.065	P_s	0.317	0.1807	0.314	0.179
φ_{s5}	1.115	1.141	1.048	1.039	W_{pump}	-224	-34.4	-558.6	-293.6
φ_{s6}	1.089	1.149	1.047	1.056	α	2.502	2.143	2.407	2.056
φ_{s7}	1.136	1.160	1.111	1.157	P_{max}	14.96	9.55	14.90	9.49
φ_{s8}	1.209	1.102	1.139	1.157	P_e	1.728	1.152	1.728	1.152

From table 1, it is seen that the scavenging coefficient of the second, fourth, fifth and sixth cylinder in MPC is very small, while the corresponding value in MIXPC is larger, and the cylinders in MIXPC have more homogenous scavenging coefficients than that in MPC have. The mean scavenging coefficient of the MIXPC turbocharging system is 1.14 at 100% load and 1.175 at 56% load, while the MPC turbocharging system has only 1.083 and 1.102. The above results mean that the scavenging interference in the MIXPC turbocharging system is small. Thus, it can be anticipated that in comparison with the MPC turbocharging system at the same operating condition of engine's power and speed the exhaust gas temperature at each cylinder outlet of the MIXPC turbocharging system will be lowered and the temperature variation will be smaller. In other words, under a given limit value of the maximum difference of the exhaust gas

temperatures at each cylinder outlet, the engine's power can be increased. These two points will be validated by the experiments reported in Section 4. Because of the lower pumping loss, the BSFC of the diesel engine using the MIXPC turbocharging system is lower than that of the diesel engine using the MPC turbocharging system. For example, the BSFC is decreased by 4.3 g/(kW·h) at 100% load and 3.9 g/(kW·h) at 56% load.

4. EXPERIMENTS ON A DIESEL ENGINE USING THE MIXPC TURBOCHARGING SYSTEM

With the validation of the MIXPC concept, experimental study of the 16V280ZJG diesel engine equipped with MIXPC has been conducted to confirm the expected gain in its performance. The 100% load operating condition of the original 16V280ZJG diesel engine is: 4200kW at 1000 r/min. The MPC turbocharging system is originally used by this engine. But the problem is that the maximum difference of the exhaust gas temperature at each cylinder outlet exceeds 150°C at 100% load, and the exhaust temperature before turbine exceeds the limit value 550°C at 50% load and 100% load. So the endurance experiment of this engine using the MPC turbocharging system does not include 100% load. It can only get to 90% load.

The MIXPC turbocharging system exhaust pipe designed for this engine, as shown in figure 7, has been manufactured and equipped on this engine, and the corresponding performances experiments have been done. It was found that the maximum difference of the exhaust gas temperature at each cylinder outlet is less than 80°C, which can be seen from table 2, and if under the restriction of the limit value 100°C, the engine load can be increased to 115%: 4830kW at 1000 r/min. The 100 hours endurance experiment including 100%, 105% and 115% load has been successfully finished. Figure 8 shows the experiment comparison of performances of this engine between the MPC turbocharging system and MIXPC. Table 3 shows the comparison of performances between experiment and simulation.

From table 2, it is seen that the maximum difference of the exhaust gas temperature at each cylinder outlet at different loads is less than 80°C. This demonstrates that the scavenging coefficients of each cylinder in the MIXPC turbocharging system are more uniform and can satisfy the scavenging requirements of this engine. From figure 8, it is seen that the exhaust gas temperature before turbine of the MIXPC turbocharging system is under 550°C. Both the exhaust gas temperature and BSFC of the MIXPC turbocharging system are lower than that of MPC. Due to the homogenous scavenging characteristics of the MIXPC turbocharging system, the engine can operate at up to 115% load. From table 3, it can be seen that the simulation results are in close agreement with the experiment results, and the relative errors are less than 2%.

Table 2. Measurements of the exhaust gas temperature at each cylinder outlet.

Operating condition	1000r/min 4200kW								
Cylinder number	1	2	3	4	5	6	7	8	$\Delta t_{\max} = 77^{\circ}\text{C}$
Temperature ($^{\circ}\text{C}$)	396	432	441	429	385	404	415	392	
Cylinder number	9	10	11	12	13	14	15	16	
Temperature ($^{\circ}\text{C}$)	399	430	401	388	400	452	396	375	
Operating condition	1000r/min 4000kW								
Cylinder number	1	2	3	4	5	6	7	8	$\Delta t_{\max} = 56^{\circ}\text{C}$
Temperature ($^{\circ}\text{C}$)	380	424	426	409	374	398	410	386	
Cylinder number	9	10	11	12	13	14	15	16	
Temperature ($^{\circ}\text{C}$)	396	416	393	379	382	435	384	396	
Operating condition	800r/min 2048kW								
Cylinder number	1	2	3	4	5	6	7	8	$\Delta t_{\max} = 65^{\circ}\text{C}$
Temperature ($^{\circ}\text{C}$)	436	422	407	439	383	428	408	401	
Cylinder number	9	10	11	12	13	14	15	16	
Temperature ($^{\circ}\text{C}$)	395	398	419	398	400	432	374	400	

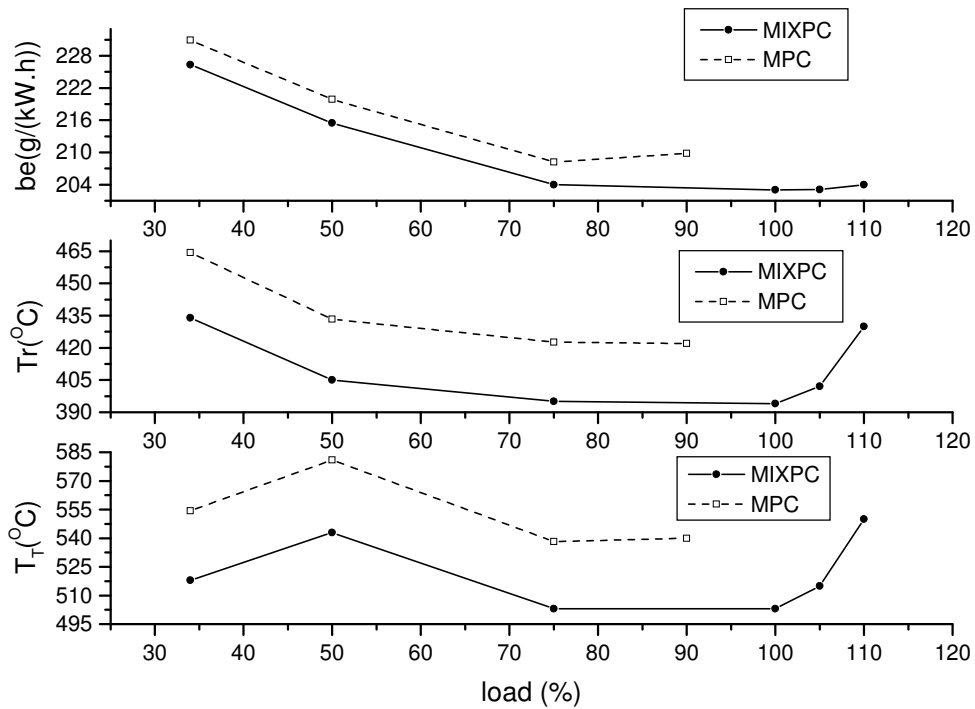

Figure 8. The experiment comparison of performances between MPC and MIXPC.

Table 3. The comparison of performances between experiment and simulation.

	100% load		75% load		50% load		25% load	
	Exp	Simu	Exp	Simu	Exp	Simu	Exp	Simu
Power(kW)	4199	4198	3107	3108	2039	2039	1375	1374
Speed(rpm)	1000	1000	920	920	800	800	700	700
P_{max}	15.3	14.96	11.7	11.9	8.22	8.39	6.5	6.39
b_e	203	203.1	204	204.1	215.5	215.2	228.7	228.1
T_T	503	513.1	503	514	543	552	515	523
G_s	4.19	4.22	2.95	2.93	1.75	1.76	1.12	1.10

5. CONCLUSIONS

- (1) A new turbocharging system, named MIXPC, has been proposed. Its main purpose is to solve the scavenging interference problem, and to lower the pumping loss in cylinders and BSFC of internal combustion engines;
- (2) By simulating a 16V280ZJG diesel engine using the MPC turbocharging system and MIXPC, it was found that not only the average scavenging coefficient of MIXPC is larger than that of MPC, but also cylinders of MIXPC have more homogeneous scavenging coefficients than that of MPC have, and the pumping loss and BSFC of MIXPC are lower than that of MPC;
- (3) The MIXPC can decrease the exhaust gas temperature before turbine and BSFC at part load, and can decrease the difference of the exhaust gas temperature at each cylinder outlet at full load, and thus diesel engines using MIXPC has the potential to increase their power.

REFERENCES

1. Watson, N. (1982). Turbocharging the Internal Combustion Engine, MACMILLAN PRESS LTD, London.
2. Capobianco, M., Gambarotta, A., and Cipolla, G. (1989). "Influence of the Pulsating Flow Operation on the Turbine Characteristics of a Small Internal Combustion Engine Turbocharger," I. Mech. E., Paper No. C372/019.
3. Capobianco, M., Gambarotta, A., and Cipolla, G. (1990). "Effect of Inlet Pulsating Pressure Characteristics on Turbine Performance of an Automotive Wastegated Turbocharger," SAE Paper No. 900359.
4. Capobianco, M., and Gambarotta, A. (1993). "Performance of a Twin-Entry Automotive Turbocharger Turbine," ASME Paper No. 93-ICE-2.

5. Yeo, J. H., and Baines, N.C. (1990). "Pulsating Flow Behavior in a Twin-Entry Vaneless Radial-Inflow Turbine," I. Mech. E., Paper No. C405/004.